

GUNDLACH

No. 295 UNI-CUTTER UNIVERSAL SEAM CUTTER

© Copyright 1995
All rights reserved.

BENO J. GUNDLACH COMPANY

Belleville, Illinois, 62222 USA

Subject to Technical Change

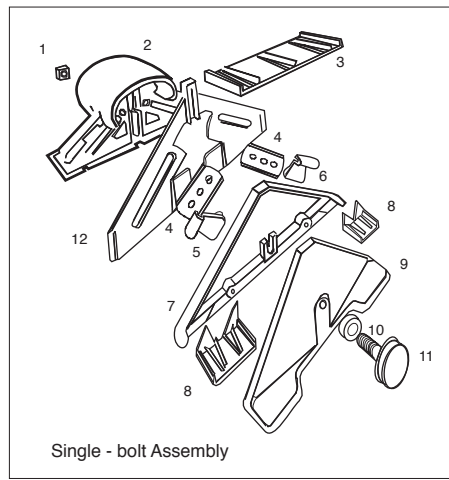

Single - bolt Assembly

Parts & Assembly

- 1 - nut
- 2 - symmetrical body handle
- 3 - replaceable shoe
- 4 - blade
- 5 - blade adjuster (L)
- 6 - blade adjuster (R)
- 7 - spacer plate
- 8 - edge guides (R&L)
- 9 - holding plate
- 10 - washer
- 11 - thumbscrew
- 12 - seam gapper

Carpet Cutting Instructions

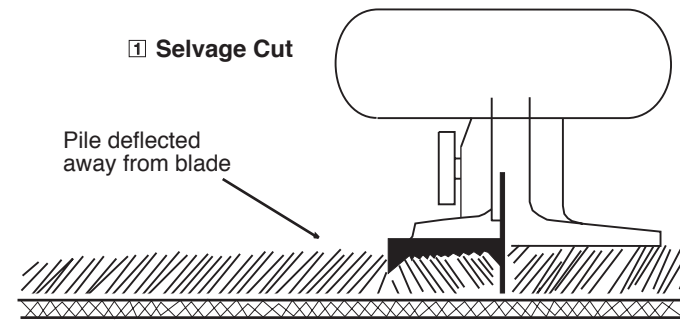

NOTE: Requires Gundlach ASE-48 or ASE-75 Straight Edge for best results with minimal pile fall-out.

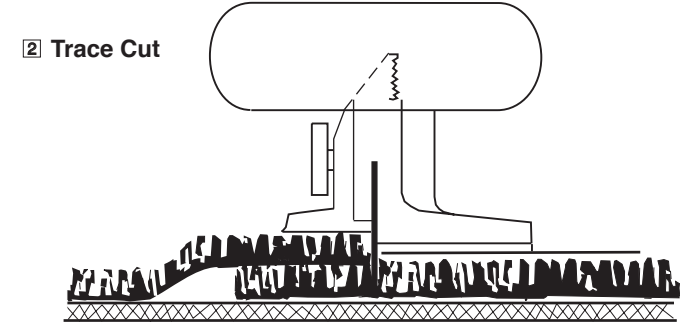

NOTE: Heavy backed and thick pile carpets may require cutting from back side to obtain a proper cut.

1 Resilient Seam Cutting Instructions

Resilient flooring materials. Overlap flooring material by 1 inch.

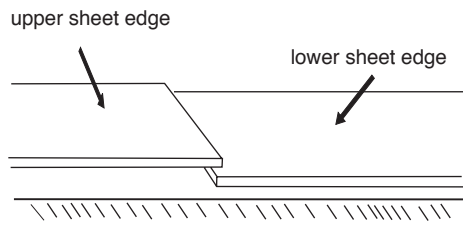

Cut through one layer of rigid flooring material (or two layers of cushioned flooring) in one pass, therefore there is no edge curl requiring de-burring as in the underscriber method.

2 Selvage Edge Cut Adjustment

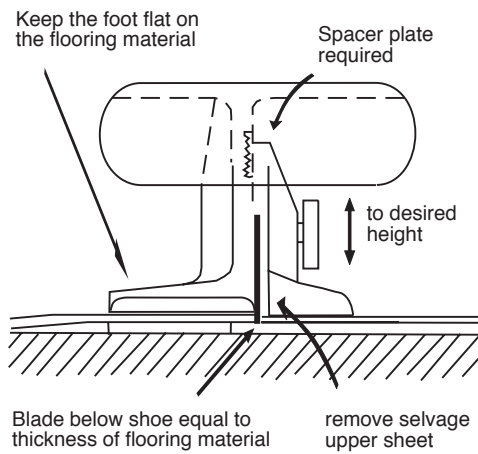

Wet surface of floor with clean damp cloth to lubricate shoe contact with resilient flooring material.

3 Selvage Edge Cutting

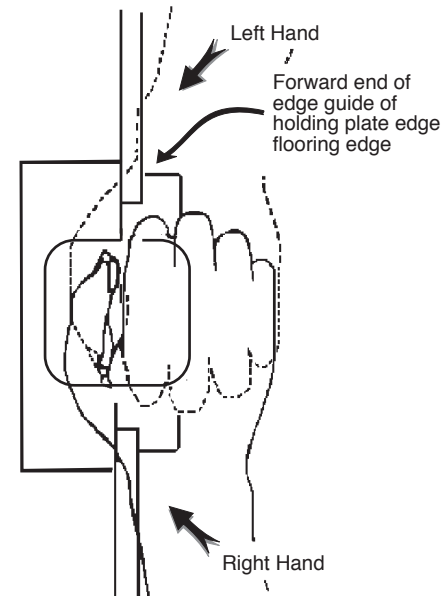

Pushing force against upper flooring edge is at an angle to the edge.

Plastic Replacement Parts

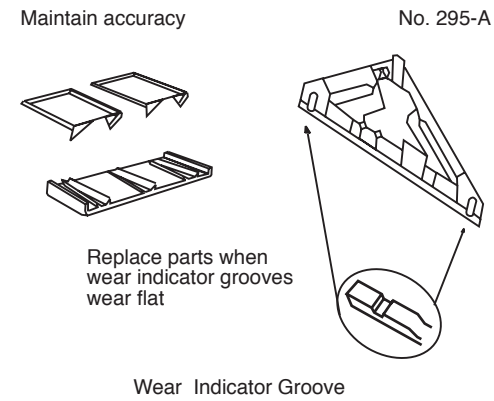

Replacement Blade

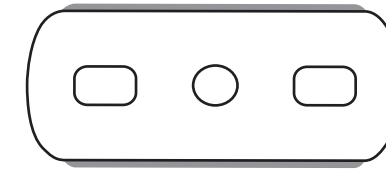

3-hole round end double-edged four cornered blades.

Available individually wrapped in packages of ten each.

Cutting Feature Strip

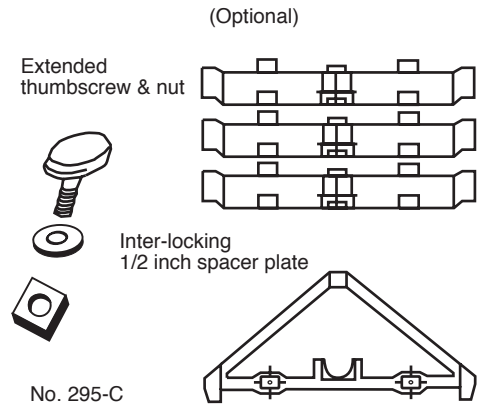

Aluminum Straight Edges

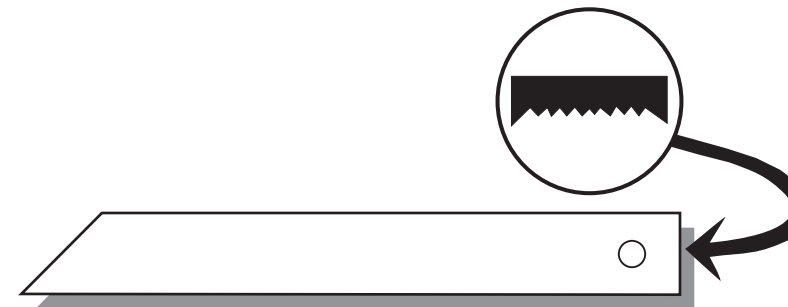

For use with carpet, the corrugated back prevents creeping of the straight edge. Made from hardened aircraft aluminum alloy with a clear anodized finish, these straight edges are lightweight. One end has a 45° miter, and a nail hole is provided in the other end. Both are 1/8" thick by 2 1/2" wide and are economically priced.

No. ASE-48 48" Long Aluminum Straight Edge
No. ASE-75 75" Long Aluminum Straight Edge

4 Trace Edge Cut Adjustment

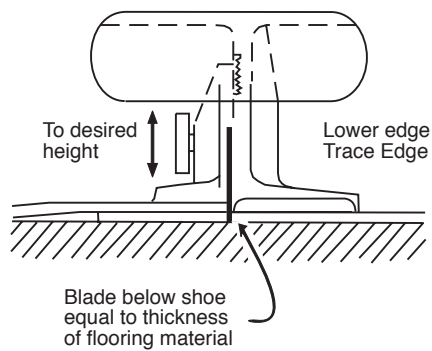

Holding plate above shoe equal to thickness of flooring material

5 Trace Edge Cutting

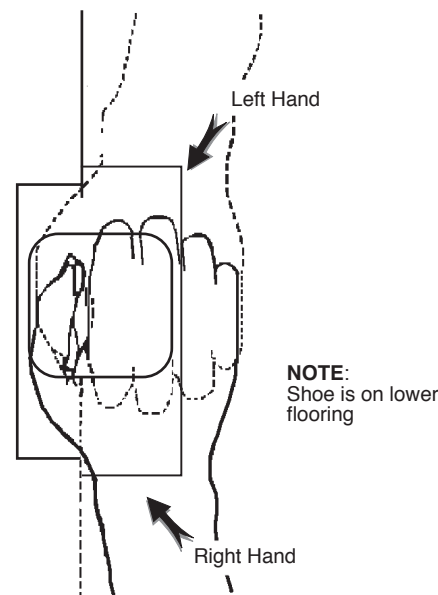

Pushing force against upper flooring edge is at an angle to the edge.

Special Feature (optional)

Trace Edge Cut SEAM GAP (Hot - welding resilient)

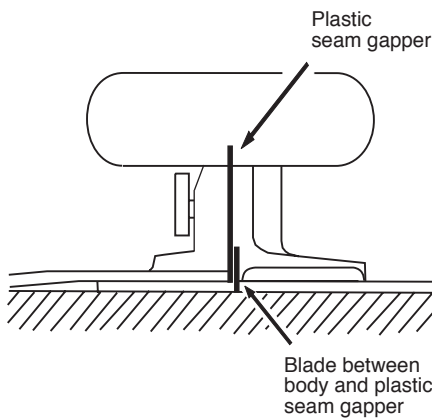

Creating a gap at the seam.

PRESENT THIS REPLACEMENT PART ORDER FORM TO YOUR DEALER.

Name: _____

Address: _____

No. 295 UNI-CUTTER PART NUMBER REQUESTED: No. 295-A Plastic replacement Parts
 No. 295-B Replacement blades

(See reverse for detail description and number for replacement parts)

OPTIONS & ACCESSORIES: No. 295-V Copy of VHS video instruction tape
 No. ASE-48 48" Long Aluminum Straight Edge
 No. ASE-75 75" Long Aluminum Straight Edge
 No. 295-C Optional Feature Strip cutting package

Contains: 3 additional 1/2" spacer plates and extended thumbscrew nut assembly

YOUR COMMENTS AND IDEAS ARE IMPORTANT TO US!

On the space provided below, please write your comments on the performance of this product, (advantages or limitations) and other uses not otherwise noted here.
